

MINI 16

System with a special head rail (20 x 19 mm) that aesthetically fits 16 mm slat. The blind is controlled with a wand for tilting and cord for lifting the slats.

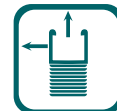
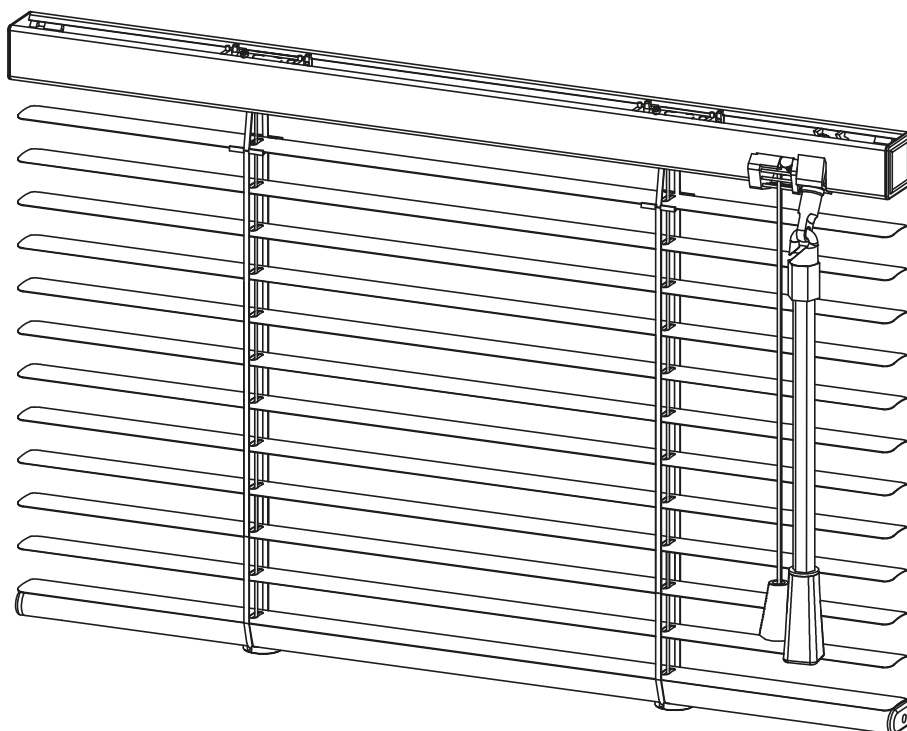

Component name

1	Aluminum 16 mm slat
2	16 mm clip
3	Head rail end cap
4	Control rod
5	Tilter
6	Tilter roll
7	20 x 19 mm head rail
8	Wand
9	Cord with PVC weight
10	Cord blocking mechanism
11	Steel or plastic line
12	Cord ladder
13	Bottom rail end cap
14	Peg*
15	Ladder cap
16	16 mm bottom rail / W POLSKIEJ WERSJI jest 25mm
17	Cord safe connector (child safety)**
18	Cord mounting- cleat (child safety)**

Holder name

19	G-BI16 bracket (noninvasive)
20	G-TU16 bracket (noninvasive)
21	G-TS16 (ceiling bracket)
22	D-K holder
23	D-KR holder*
24	D-STR holder*
25	D-KS holder*
26	D-KPCV holder (transparent)*
27	D-KP holder*
28	D-BI holder (noninvasive)*
29	D-MG holder (with magnet)

* If the blind has side guidance
** Optional

